

**WARNING: Do Not Operate Before Reading Manual**

# Qx OPERATOR'S MANUAL

Models

3200    4600    6000



**Disclaimer Statement:**

All information, illustrations and specifications in this manual are based on the latest information available at the time of publishing. The illustrations used in this manual are intended as representative reference views only. Products are under a continuous improvement policy. Thus, information, illustrations and/or specifications to explain and/or exemplify a product, service or maintenance improvement may be changed at any time without notice.

**Rights Reserved Statement:**

No part of this publication may be reproduced or used in any form by any means – graphic, electronic or mechanical, including photocopying, recording, taping or information storage and retrieval systems – without the written permission of Tuthill Vacuum & Blower Systems.

# Table of Contents

<b>Introduction .....</b>	<b>1</b>
<b>Safety .....</b>	<b>2</b>
Graphic Conventions Used in this Manual.....	2
Safety Instructions.....	2
Safety Precautions .....	3
Protective Materials.....	4
<b>Installation .....</b>	<b>5</b>
Operating Characteristics .....	5
Operating Limitations .....	5
Specifications Table .....	6
Start-Up Checklist.....	7
Foundation .....	8
Location .....	8
Soft Foot .....	8
Mounting Stress .....	9
Blower Air Intake .....	9
Motor Drives .....	9
Direct Coupled.....	9
V-Belts .....	9
Electrical Connections .....	10
Relief Valves.....	10
Piping.....	10
Lubrication (Splash).....	11
Frequently Asked Questions Regarding Lubrication .....	12

<b>Operation .....</b>	<b>13</b>
Recommended Shutdown Procedure to Minimize Risk of Freezing or Corrosion .....	13
Long Term Storage .....	14
<b>Maintenance .....</b>	<b>15</b>
General .....	15
Regular Maintenance .....	15
Preventative Maintenance .....	16
Troubleshooting.....	17
Repair and Replacement Parts.....	19
Factory Service and Repair .....	19
<b>Disassembly and Reassembly Instructions .....</b>	<b>20</b>
Disassembly (3200 and 4600) .....	20
Disassembly (6000 Series) .....	22
Assembly (3200 and 4600).....	22
Gear End Assembly (3200 and 4600).....	23
Drive End (Free End) Assembly (3200 and 4600).....	23
Assembly (6000 Series) .....	24
Gear End Assembly (6000 Series).....	24
Drive End (Free End) Assembly (6000 Series).....	24
<b>Assembly Clearances .....</b>	<b>25</b>
<b>Recommended Lubricants for Rotary Blowers and Vacuum Boosters.....</b>	<b>26</b>
<b>Cutaway Drawings and Parts Lists .....</b>	<b>28</b>
Cutaway Drawing for Qx-3200 and Qx-4600 Series Blowers .....	28
Parts List for Qx-3200 and Qx-4600 Series Blowers .....	29
Cutaway Drawing for Qx-6000 Series Blowers .....	30
Parts List for Qx-6000 Series Blowers .....	31
<b>Declaration of Incorporation .....</b>	<b>32</b>
<b>Warranty – Blower Products .....</b>	<b>33</b>
<b>Operating Data Form / Product Registration.....</b>	<b>34</b>

**CONGRATULATIONS** on the purchase of a new Qx<sup>®</sup> Rotary Positive Displacement Air Blower from Tuthill Vacuum & Blower Systems. Please examine the blower for shipping damage, and if any damage is found, report it immediately to the carrier. If the blower is to be installed at a later date, make sure it is stored in a clean, dry location and rotated regularly. Make sure covers are kept on all openings. If the blower is stored outdoors, be sure to protect it from weather and corrosion.

Qx blowers are built to exacting standards and, if properly installed and maintained, will provide many years of reliable service. Read and follow every step of these instructions when installing and maintaining the blower.

 **WARNING**

Serious injury can result from operating or repairing this machine without first reading the operating manual and taking adequate safety precautions.

**NOTE:** Record the blower model and serial number of the machine in the **OPERATING DATA FORM** on the inside back cover of this manual. Use this identification on any replacement part orders, or if service or application assistance is required.

# 02

## SAFETY

### GRAPHIC CONVENTIONS USED IN THIS MANUAL

The following hazard levels are referenced within this manual:

#### **DANGER**

Indicates a hazardous situation that, if not avoided, will result in death or serious injury.

#### **WARNING**

Indicates a hazardous situation that, if not avoided, could result in death or serious injury.

#### **CAUTION**

Indicates a hazardous situation that, if not avoided, could result in minor or moderate injury.

#### **NOTICE**

*Indicates a situation that can cause damage to the engine, personal property, and/or the environment or cause the equipment to operate improperly.*

**NOTE:** Indicates a procedure, practice, or condition that should be followed in order for the equipment to function in the manner intended.

### SAFETY INSTRUCTIONS

1. Do not operate before reading the enclosed operating manual.
2. Use adequate protection, warning and safety equipment necessary to protect against hazards involved in installation and operation of this equipment.

#### **NOTICE**

- *The safety instruction tags shown below were attached to your unit prior to shipment. Do not remove, paint over or obscure in any manner.*
- *Failure to heed these warnings could result in serious bodily injury to the personnel operating and maintaining this equipment.*

#### **WARNING**



**Keep body and clothing away from machine openings.**

 <b>WARNING</b>	
	<b>Hearing protection required.</b>

 <b>CAUTION</b>	
	<b>Do not operate without guards in place.</b>

 <b>CAUTION</b>	
	<b>Do not touch hot surfaces.</b>

 <b>WARNING</b>	
<ul style="list-style-type: none"> <li>• <b>Keep hands and clothing away from rotating machinery, inlet and discharge openings.</b></li> <li>• <b>Blower and drive mounting bolts must be secured.</b></li> <li>• <b>Drive belts and coupling guards must be in place.</b></li> <li>• <b>Noise level may require ear protection.</b></li> <li>• <b>Blower heat can cause burns if touched.</b></li> </ul>	

## Safety Precautions

For equipment covered specifically or indirectly in this operating manual, it is important that all personnel observe safety precautions to minimize the chances of injury. Among many considerations, the following should particularly be noted:

- Blower casing and associated piping or accessories may become hot enough to cause major skin burns on contact.
- Internal and external rotating parts of the blower and driving equipment can produce serious physical injuries. Do not reach into any opening in the blower while it is operating or while subject to accidental starting. Cover external moving parts with adequate guards.
- Disconnect power before doing any work, and avoid bypassing or rendering inoperative any safety or protective devices.
- If blower is operated with its piping disconnected, place a strong, coarse screen over the inlet and avoid standing in discharge air stream.
- Avoid extended exposure in close proximity to machinery with high intensity noise levels.
- Use proper care and good procedures in handling, lifting, installing, operating, and maintaining the equipment.
- Other potential hazards to safety may be associated with operation of this equipment. All personnel working in or passing through the area should be warned by signs and trained to exercise adequate general safety precautions.
- Hearing protection may be required depending on silencing capabilities.

**CAUTION**

Customers are cautioned to provide adequate protection, warning and safety equipment necessary to protect personnel against hazards involved in the installation and operation of this equipment in the system or facility.

**WARNING**

Do not use air blowers on explosive or hazardous gases. Each size blower has limits on pressure differential, running speed, and discharge temperature, which must not be exceeded. Consult *Specifications Table 3-1* on page 6.

## PROTECTIVE MATERIALS

- Remove protective materials from the shaft.
- Remove the protective covers from the inlet and outlet ports, and inspect the interior for dirt and foreign material.

**WARNING**

Keep hands, feet, foreign objects, and loose clothing from inlet and outlet openings to avoid injury or damage if lobes are to be rotated at this point.

The blower housing and associated piping or accessories may become hot enough to cause major skin burns on contact. Internal and external rotating parts of the blower and driving equipment can produce serious physical injuries. Never run the blower with the inlet or discharge piping removed. If it becomes necessary to inspect the rotating parts of the blower or to change V-belts, be absolutely sure that all power to the motor controls has been shut off and that the motor controls are locked out and have been properly tagged before proceeding.

**WARNING**

Avoid extended exposure in close proximity to machinery with high intensity noise levels. Always wear adequate ear protection. Use proper care and good procedures in handling, lifting, installing, operating, and maintaining the equipment.

**CAUTION**

Use proper care and good procedures in handling, lifting, installing, operating and maintaining the equipment.



### Operating Characteristics

Qx blowers are rotary positive displacement type units with tri-lobe rotors rotating in opposite directions within a housing closed at the ends by end plates. The pumping capacity is determined by size, operating speed, and differential pressure conditions.

The inlet to the discharge is sealed with operating clearances that are very small. Internal lubrication is not needed, as there is no moving contact.

Clearances between the rotors during rotation are maintained by a pair of accurately machined helical timing gears, mounted on the two shafts extended outside the air chamber. The two intermeshing rotary lobes are designed to rotate and trap air or gas between each rotor and the housing. As the rotor lobes rotate past the edge of the suction port, the trapped air or gas is essentially at suction pressure and temperature. Since the blower is a constant volume device, the trapped air remains at suction pressure until the leading rotor lobe opens into the discharge port. The close clearances between the rotors inhibit back slippage of the trapped volume from between the rotors, and the trapped volume is forced into the discharge piping. Compression occurs not internal to the blower but by the amount of restriction, either downstream of the blower discharge port or upstream of the blower inlet port.

Air moves not between the rotors but between the rotors and the side of the housing. Also, the machine is bi-directional, meaning that the direction of rotation of the blower can make either side the inlet or discharge. See also **Figure 3-1 on page 6**, Flow Direction by Rotation.

Protect the blowers with cut-in switches or bypass valving to limit differential pressure across the blower. **See Operating Limitations on page 5** for more information. When a belt drive is used, it is possible to adjust blower speed to obtain the desired capacity by changing the diameter of one or both sheaves, or by using a variable-speed motor pulley.

### Operating Limitations

To permit continued satisfactory performance, a blower must be operated within certain conditions. The manufacturer's warranty is contingent on such operation. Maximum limits for temperature and speed are specified in **Table 3-1 on page 6** for various blower sizes when operated under the standard atmospheric conditions. Do not exceed these limits.

**EXAMPLE:** Seldom does the operation of a blower result in pressure differentials large enough to strain the blower drive train (bearings, gears, and seals). Typically, the maximum allowable temperature limit (the limit is a function of the temperature rise as well as the inlet temperature) for any particular blower may occur well before the maximum speed or allowable power rating is reached. Temperature rise then becomes the limiting condition. The operating limit is to be determined by the maximum rating reached first, and it can be any one of the following: temperature, speed, or horsepower.

**NOTE:** Specially ordered blowers with non-standard construction, or with rotor end clearances greater than shown in this manual, will not have the operating limits specified in *Specifications Table 3-1* on page 6. Contact your Tuthill Vacuum & Blower Systems sales representative for specific information.

## Specifications Table

MODEL	SERIES	PORT SIZE	APPROXIMATE OIL CAPACITY		MAXIMUM ALLOWABLE DISCHARGE TEMPERATURE	MAXIMUM TEMPERATURE RISE	MAXIMUM PRESSURE	MAXIMUM VACUUM	MAXIMUM RPM
			VERTICAL FLOW	HORIZONTAL FLOW					
3203 3205 3208 3213	AA	2 in. (51 mm) 3 in. (76 mm) 4 in. (102 mm) 4 in. (102 mm)	0.68 qt (0.64 L)	0.38 qt (0.36 L)	445°F (229°C)	325°F (163°C)	18 psig	17 inch-Hg (576 mbar)	4,800
4606 4610 4616	AA	4 in. (102 mm) 6 in. (152 mm) 6 in. (152 mm)	1.82 qt (1.1 L)	1.07 qt (1 L)	445°F (229°C)	325°F (163°C)	18 psig	17 inch-Hg/ (576 mbar)	4,000
6009 6015 6024	AA	8 in. (203 mm) 8 in. (203 mm) 10 in. (254 mm)	4.68 qt (4.4 L)	2.63 qt (2.5 L)	445°F (229°C)	325°F (163°C)	18 psig	17 inch-Hg (576 mbar)	3,200

Table 3-1 – Specifications

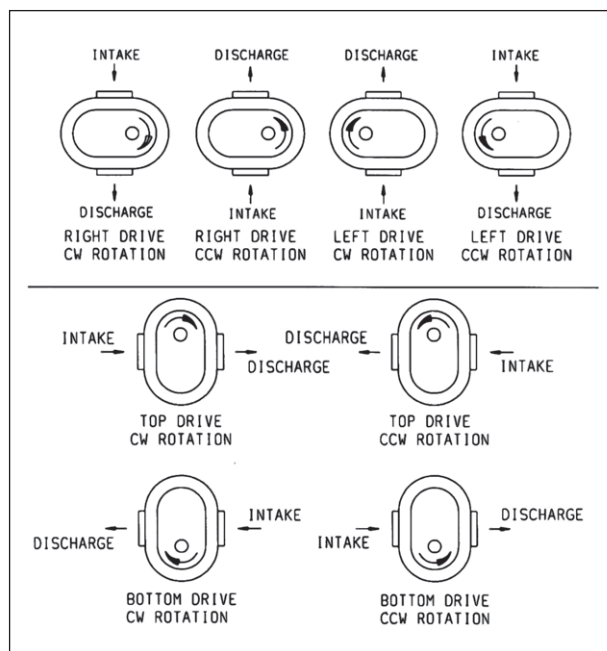

Figure 3-1 – Flow Direction by Rotation

## START-UP CHECKLIST

It is recommended that these start-up procedures be followed in sequence and checked off (  ) in the boxes provided in any of the following cases.

<ul style="list-style-type: none"> <li>• During initial installation</li> <li>• After any shutdown period</li> </ul>	<ul style="list-style-type: none"> <li>• After maintenance work has been performed</li> <li>• After blower has been moved to a new location</li> </ul>
<b>DATES CHECKED:</b>	<input type="text"/> <input type="text"/> <input type="text"/>
<input type="checkbox"/> <input type="checkbox"/> <input type="checkbox"/> <input type="checkbox"/>	Check the unit for proper lubrication. Proper oil level is critical. <b>See <i>Lubrication (Splash)</i> on page 11. See <i>Recommended Lubricants for Rotary Blowers and Vacuum Boosters</i> on page 26</b> for information on acceptable lubricants for the product.
<input type="checkbox"/> <input type="checkbox"/> <input type="checkbox"/> <input type="checkbox"/>	Check the V-belt drive for proper belt alignment and tension. <b>See <i>V-Belts</i> on page 9.</b>
<input type="checkbox"/> <input type="checkbox"/> <input type="checkbox"/> <input type="checkbox"/>	Carefully turn the rotors by hand to be certain they do not bind.

### WARNING

Disconnect power. Make certain power is off and locked out before touching any rotating element of the blower, motor, or drive components.

### WARNING

When touching the blower or motor during operation, make certain that loose clothing, long hair, neckties, loose shoelaces, rags, etc. are secured snugly and cannot accidentally dangle into rotating elements such as shafts, belts, and sheaves.

<input type="checkbox"/> <input type="checkbox"/> <input type="checkbox"/> <input type="checkbox"/>	“Bump”* the unit with the motor to check rotation (counterclockwise when facing the shaft) and to be certain it turns freely and smoothly.
<input type="checkbox"/> <input type="checkbox"/> <input type="checkbox"/> <input type="checkbox"/>	Start the unit and operate it for 30 minutes at no load. During this time, feel the cylinder for hot spots. If minor hot spots occur, <b>see <i>Troubleshooting</i> on page 17.</b>
<input type="checkbox"/> <input type="checkbox"/> <input type="checkbox"/> <input type="checkbox"/>	Apply the load and observe the operation of the unit for 1 hour.
<input type="checkbox"/> <input type="checkbox"/> <input type="checkbox"/> <input type="checkbox"/>	If minor malfunctions occur, discontinue operation and <b>see <i>Troubleshooting</i> on page 18.</b>

\* Start intermittently and then turn off immediately.

## FOUNDATION

The blower does not need a special foundation. However, it does require a solid, level floor and adequate frame support.

## LOCATION

Install the blower in a protected indoor location, if possible. An unprotected outdoor installation is satisfactory only when correct lubrication for the expected temperatures is provided. **See *Recommended Lubricants for Rotary Blowers and Vacuum Boosters on page 26***. Just before starting the installation, remove plugs or covers from inlet and discharge connections. Inspect for dirt or foreign objects inside machine, and then turn the drive shaft by hand to make sure it rotates freely. Mount in a level position. Use a baseplate that is rigid, solidly supported, and structurally sound. Make sure the feet rest evenly on the plate before fastening down. Twisting or cramping the blower during mounting will cause rotor contact and binding during operation.

## SOFT FOOT

Soft foot is a condition in which one of the blower feet does not sit flat on the base. Usually, this is due to irregularities in the surface to which the blower is mounted. When you tighten the bolt on the foot, the blower will distort slightly, but enough to cause problems with bearing and seal life, and premature internal contact between the rotors and the housing.

1. Place blower on base.
2. Check each foot for gaps between foot and base (soft foot), shim as necessary to fill gap within .002 in. (.05 mm). Below are shown the two most common types of soft foot conditions. If either type is present, and measures more than .003 in. (.076 mm), the blower may fail prematurely.
3. Tighten all bolts.
4. Mount a dial indicator on base contacting one foot at 12 o'clock position.

5. Loosen bolt on that foot. Observe indicator travel and add shims as needed to reduce "spring" to less than .002 in. (.05 mm). Repeat steps 4 and 5 on remaining feet.

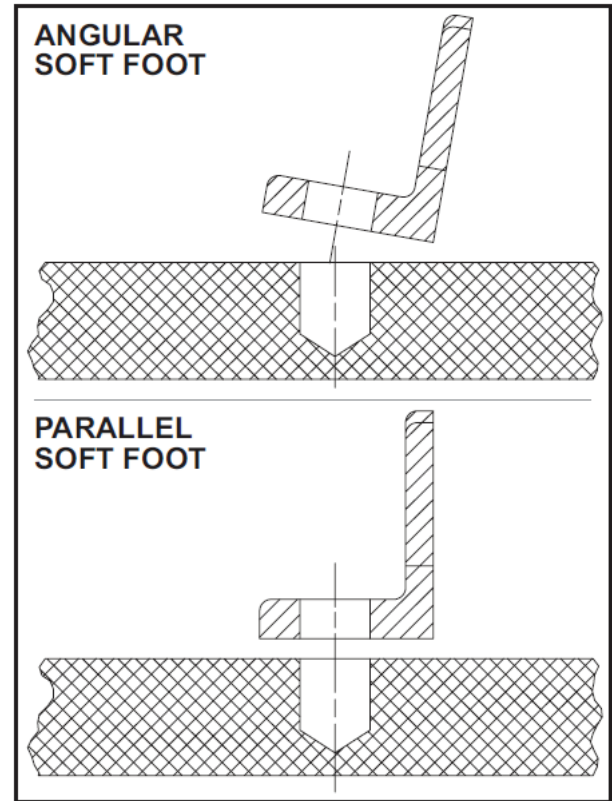

Figure 3-2 – Illustrations of Soft Foot

Transmission of small operating vibrations to a support structure may be objectionable in some applications. Use of vibration isolators or vibration-absorbing materials can be effective in overcoming this transmission. To avoid causing distortion, apply the treatment under the common motor/blower base or mounting plate rather than directly under the feet alone. Make sure piping is accurately squared with the blower and supported independently. Use only clean, new pipe, and make certain it is free of scale, cuttings, weld beads, dirt, or any other foreign material.

To guard against damage to the blower, make sure that an inlet filter is used. Clean the filter of collected debris after 3 hours of operation and periodically thereafter.

## MOUNTING STRESS

Stress imparted from incorrectly aligned piping or mounting will create problems with bearing and seal life, possibly leading to premature internal contact. The blower should sit stress-free and evenly on its supporting surface. Take care to evenly tighten the mounting bolts to avoid imparting undue stress into the blower. Stress can be checked in a free state with feeler stock or verified on a previously installed blower with the aid of a dial indicator. Spring or gap should be less than 0.002 in. (0.05 mm).

## BLOWER AIR INTAKE

To minimize maintenance, supply the blower with the cleanest air possible. The air must not contain any flammable or toxic gases, as the blower will concentrate these gases. This could result in damage to the blower and surrounding property and lead to personal injury or death.

### WARNING

**Do not use air blowers on explosive or hazardous gases. Each size blower has limits on pressure differential, running speed, and discharge temperature. These limits must not be exceeded.**

If it is necessary to take air from a remote source, such as in a vacuum application, make sure the diameter of the piping is at least the equal to the diameter of the blower inlet. For distances greater than 20 ft (6 m), enlarge the pipe diameter to reduce inlet restriction. Excessive restriction will reduce the efficiency of the blower and elevate its discharge temperature.

The piping used should also be corrosion-resistant and free of scale and dirt. Keep the inlet covered to keep out foreign objects and rain.

## MOTOR DRIVES

Two drive connections commonly used are direct drive and V-belt drive.

## DIRECT COUPLED

When installing the motor directly to the blower, align the shafts to the coupling according to the coupling manufacturer's instructions.

Blowers shipped with motor directly coupled and mounted on a common base have been aligned prior to shipment. Further alignment is not normally necessary, but be sure to check the alignment and make adjustments if necessary prior to starting the blower.

## V-BELTS

If the motor and blower are V-belt connected, the sheaves on both the motor and blower shafts should be as close to the shaft bearings as possible. Blower sheave is not more than 1/4 in. (6.5 mm) from the blower drive end cover. The drive sheave is as close to the driver bearing as possible. Take care when installing sheaves on the blower and motor shafts. Make sure the face is accurately in line to minimize belt wear.

Adjust the belt tension to the manufacturer's specifications using a belt tension tester. Check new belts for proper tension after 24 hours of run time. When manufacturer data is not available, industry guidelines recommend 1/64 in. deflection for each inch of span (0.157 mm deflection per centimeter of span) at 8 to 10 lb (3.6 – 4.5 kg) of force in the center of the belt. **See Figure 3-3.**

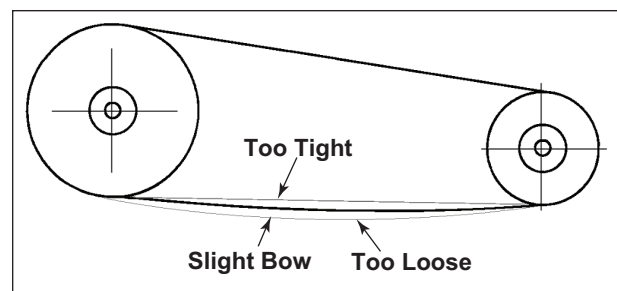

Figure 3-3 – General appearance of V-belt drive

Insufficient tensioning is often indicated by slipping (squealing) at start-up. Do not use belt dressing on V-belts. Keep sheaves and V-belts free of oil and grease. Removed tension from belts if the drive is to be inactive for an extended period of time. For more specific information, consult the drive manufacturer. In a V-belt drive, the blower sheave must fit its shaft accurately, run true, and be mounted as close to the bearing housing as possible to minimize bearing loads. **See Figure 3-4.**

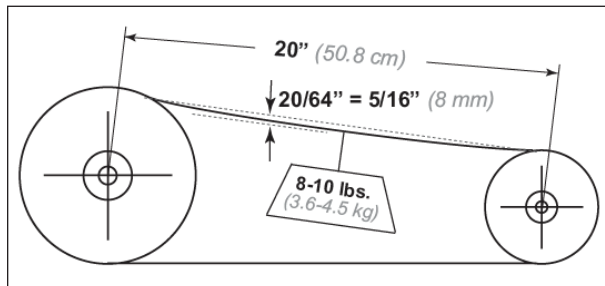

Figure 3-4 – Setting of proper tension for a V-belt drive

A tight or driving fit will force the drive shaft out of its normal position and cause internal damage. A loose fit will result in shaft damage or breaking. Make sure the motor sheave fits correctly and is properly aligned with the blower sheave.

Adjust the motor position on its sliding base so that belt tension is in accordance with the drive manufacturer's instructions. Always avoid excessive belt tension. Recheck tension after the first 10 hours of operation and periodically thereafter to avoid slippage and loss of blower speed.

Check the blower after installation and before applying power by rotating the drive shaft by hand. If the drive shaft does not rotate freely:

- Look for uneven mounting, piping strain, excessive belt tension, or coupling misalignment.
- Check the blower to make sure oil was added to the reservoirs.

## ELECTRICAL CONNECTIONS

Wire the motor and other electrical devices, such as solenoid valves and temperature switch, to the proper voltage and amperage as indicated on the nameplate of each component being wired. Turn the blower by hand after wiring is completed to determine that there are no obstructions, and that the blower turns freely. Then, momentarily start the blower to check the direction of rotation. The airflow direction can be reversed by reversing the appropriate motor leads.

## RELIEF VALVES

Tuthill recommends the use of relief valves to protect against excessive pressure or vacuum conditions. Test these valves at initial start-up to be sure they are properly adjusted to relieve at or below the maximum pressure differential rating of the blower.

### CAUTION

**Upon completion of the installation, and before applying power, rotate the drive shaft by hand. It must move freely. If it does not, look for uneven mounting, piping strain, excessive belt tension, coupling misalignment or any other cause for binding. If blower is removed and still does not rotate freely, check inside the blower housing for foreign material.**

## PIPING

- Ensure that inlet and outlet connections on all blowers are large enough to handle maximum volume with minimum friction loss. Inlet and outlet connections on all blowers are large enough to handle maximum volume with minimum friction loss.
- Maintain same-diameter piping.
- Do not support silencers by the blower.
- Avoid stress loads and bending moments.

Be certain all piping is clean internally before connecting to the blower. Place a 16-mesh wire screen backed with hardware cloth at or near the inlet connections for the first 50 hours of use until the system is clean. Clean the screen after 3 hours of operation and completely discard it once the system is clean, as it will eventually deteriorate and small pieces going into the blower can cause serious damage. A horizontal or vertical airflow piping configuration is easily achieved by rearranging the mounting feet position.



### WARNING

Do not operate equipment without adequate silencing devices since high noise level may cause hearing damage. (Reference OSHA Standards).

## LUBRICATION (SPLASH)

Before starting the unit, fill oil reservoirs as instructed below:

1. Remove fill plugs or breathers from the gear (drive) end and free (non-drive) end plates.
2. Pour oil through the fill hole until oil appears in the sight glass. Slowly bring oil up to center of glass. Repeat for both end plates. Fill each oil sump independently.
3. Re-seal plugs and reinstall in end plates.
4. Check oil levels frequently. Shut down the blower to properly check oil levels.

### PLEASE NOTE THE FOLLOWING:

- Every Tuthill Vacuum & Blower Systems blower has been factory-tested, oil-drained, and shipped dry.
- Fill oil reservoirs to the proper level before operation.

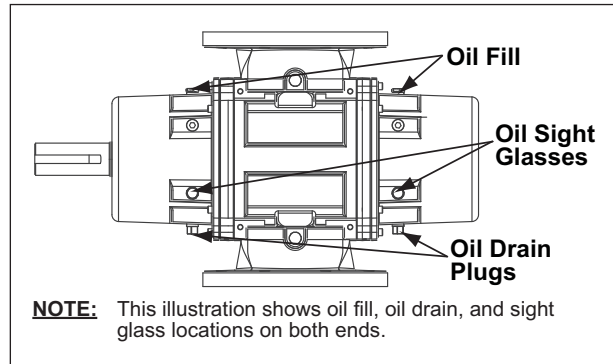

Figure 3-5 – Locations of Oil Fill, Oil Drain Plug, and Oil Sight Glass

- See **Recommended Lubricants for Rotary Blowers and Vacuum Boosters on page 26** for lubricants approved for use in Tuthill blowers.
- Add oil in the quantity shown in **Specifications Table 3-1 on page 6**.
- Time lapse between oil changes will vary depending on operating conditions.
- Higher blower operating temperatures are directly related to higher oil temperatures.

## FREQUENTLY ASKED QUESTIONS REGARDING LUBRICATION

*What are the perceived modes of failure when blowers are run beyond the specified duty cycles?*

Several things are happening as the lubricant goes through the unit. First, it is absorbing frictional energy in the form of heat. This heat has to be dissipated through either surface contact with cooler materials or in a volume of lubricant. While reducing the friction, the lubricant is also going through a shearing process and the molecular structure is broken down.

The result is that the lubricant will begin to thicken because of the shorter molecular chains and the drop out of additive packages. The thickened lubricant will cause more drag, increasing the friction and heat and further degrading the lubricant.

Operation of the blower (environment, run time, speed, and pressure) has a direct effect on duty cycles. The published cycles are based on worst-case conditions.

*What is the functional detriment if the “wrong oil” is used?*

The lubricant is selected based on bearing speed, gear speed, and operating temperature. If the lubricant is too light, it increases wear by not separating the sliding surfaces and it will not remove the heat adequately. If the lubricant is too thick, the drag in the bearings is increased, causing them to run hotter. Thicker lubricant will not flow as readily into the gears and it will reduce the available backlash. Lubricants at our conditions are incompressible.

*What is the functional detriment if the oil is not serviced?*

If the lubricant is not serviced at the proper interval, the shearing action in the bearing and the gears will begin to take its toll and the lubricant will thicken. The blower will run hotter and the wear on moving parts will increase. The lubricant will generally appear dirtier, caused by material rubbing off the components. The lubricant will discolor because of overheating. An indicator of the breakdown of a lubricant is the increase in the Total Acid Number (TAN) and a change of 10 percent in the base viscosity.



Before starting the blower for the first time under power, recheck the installation thoroughly to reduce the likelihood of difficulties. Use the following checklist as a guide, but consider any other special conditions in your installation.

1. Be certain no bolts, rags, or dirt have been left in the blower.
2. Be certain that inlet piping is free of debris. If an open outdoor air intake is used, be sure the opening is clean and protected by an inlet filter. This also applies to indoor use.
3. If installation is not recent, check blower leveling, drive alignment, belt tension, and tightness of all mounting bolts.
4. Be certain the proper volume of oil is in the oil reservoir chambers.
5. Be certain the driving motor is properly lubricated and connected through suitable electrical overload devices.
6. With electrical power off and locked out to prevent accidental starting, rotate the blower shaft several times by hand to make sure the blower is rotating freely. Unevenness or tight spots are indicators of a condition that should be corrected before progressing.
7. Check motor rotation by momentarily pushing the START button and then checking the flow direction of the blower. Reverse the motor connections if the flow is in the wrong direction.

Carry out initial operation under “no load” conditions by opening all valves and venting the discharge to atmosphere, if possible. Then, start the motor briefly, listen for unusual noises, and make sure the blower coasts freely to a stop. If no problem appears, repeat this check, and let the motor run slightly longer. If any questions exist, investigate before proceeding.

Assuming all tests are satisfactory, the blower will now be ready for continuous full-load operation. During the first several days, check periodically to make sure all conditions remain acceptable and steady. These checks may be particularly important if the blower is part of a process system where conditions may vary. At the first opportunity, stop the blower and clean or remove the inlet filter. Also recheck leveling, coupling alignment or belt tension, and mounting bolts for tightness.

### RECOMMENDED SHUTDOWN PROCEDURE TO MINIMIZE RISK OF FREEZING OR CORROSION

When a blower is taken out of service, it may require internal protection against rusting or corrosion. The need for such protection must be a matter of judgment based on existing conditions as well as length of down time. Under atmospheric conditions producing rapid corrosion, the blower should be protected immediately. When an air piping system has high humidity or moisture, water condensation can occur after the blower is shut down and it begins to cool. Condensation creates an environment favorable to corrosion of

the iron internal surfaces and to ice formation in cold weather. Both of these conditions can close the operating clearances, causing the blower to fail upon future start-up.

The following shutdown procedure minimizes the risk of moisture condensation, corrosion, and freezing.

### NOTICE

*Care must be taken to avoid overloading or overheating.*

1. Isolate the blower from the moist system piping, allowing the blower to intake atmospheric air.
2. Operate the blower under a slight load, allowing the blower to heat within safe limits. The heat generated by the blower will quickly evaporate residual moisture.
3. For carpet cleaning applications, after the work is completed, simply allow the blower to run 3 – 5 minutes with the suction hose and wand attached. The suction hose and wand will provide enough load to the blower to evaporate the moisture quickly.
4. For extended shutdown, inject a small amount of a light lubricating oil such as 3-in-One®\* or a spray lubricant such as WD-40®\* into the inlet of the blower just before shutdown. The lubricant will provide an excellent protective coating on the internal surfaces. If using a spray lubricant, take care to prevent the applicator tube from getting sucked into the blower. The applicator tube will damage the blower, likely to a degree where repair would be required.

\* 3-in-One and WD-40 are registered trademarks of WD-40 Company.

## LONG TERM STORAGE

1. Spray the interior (lobes, housing, and end plates) with rust preventative.
2. Apply a rust preventative grease to the drive shaft.
3. Attach a desiccant bag to either of the covers to prevent condensation from occurring inside the blower. Make sure any desiccant bag (or bags) is attached to the covers so that they will be removed before start-up of the blower.
4. Store the blower in an air conditioned and heated building if possible. If air conditioned and heated storage is not possible, make conditions as dry as possible.
5. If possible, rotate the drive shaft by hand at least monthly in order to prevent seals from setting in one position.

### GENERAL

Regular inspection of the blower and its installation, along with complete checks on operating conditions, will pay dividends in added life and usefulness. Also, service the drive per the manufacturer's instructions and lubricate the coupling or check the belt drive tension. Use thermometers and gauges to make sure that blower operating temperature and pressure remain within allowed limits.

### REGULAR MAINTENANCE

A well-designed maintenance program will add years of service to the blower.

Check a newly installed blower frequently during the first month of operation, especially lubrication. With the blower at rest, check the oil level in both the gear (drive) end and free (non-drive) end of the blower and add oil as needed. Complete oil changes are recommended every 1,000 – 1,200 operating hours, or more frequently depending on the type of oil and operating temperature. Also change the oil more frequently if pumping corrosive vapors or where excessive operating temperatures are encountered.



#### DANGER



The blower and parts may contain hazardous media. Assure that pump and parts are evacuated of hazardous media prior to servicing.



#### CAUTION

The electrical service must be isolated and de-energized prior to maintenance. Apply appropriate procedures to assure electrical supply is de-energized and cannot be inadvertently energized during maintenance.

Assure piping and product is isolated prior to maintenance of blower. Apply appropriate procedures to assure piping and product is isolated and that inadvertent opening of valves cannot occur during maintenance.



#### CAUTION

During routine maintenance, inspect and assure that guards are in place and secure.

When a blower is taken out of service, it may require internal protection against rusting or corrosion. The need for such protection must be a matter of judgment based on existing conditions as well as length of downtime. Under atmospheric conditions producing rapid corrosion, protect the blower immediately. **See Long Term Storage on page 14.**

## PREVENTATIVE MAINTENANCE

The following is recommended as a minimum maintenance program.

DAILY	WEEKLY	MONTHLY
<ol style="list-style-type: none"> <li>1. Check and maintain oil level, and add oil as necessary.</li> <li>2. Check for unusual noise or vibration (<b>See Troubleshooting on page 17</b>).</li> </ol>	<ol style="list-style-type: none"> <li>1. Clean all air filters. A clogged air filter can seriously affect the efficiency of the blower and cause overheating and increased oil usage. Replace if necessary.</li> <li>2. Check the relief valve to make sure it is operating properly.</li> </ol>	<ol style="list-style-type: none"> <li>1. Inspect the entire system for leaks.</li> <li>2. Inspect the condition of oil and change if necessary.</li> <li>3. Check drive belt tension and tighten if necessary.</li> </ol>

### NOTICE

*Oil levels should be checked every 24 hours of operation.*

Proper oil drain schedules require oil be changed before the contaminant load becomes so great that the lubricating function of the oil is impaired or heavy disposition of suspended contaminants occurs. To check the condition of the oil, drain a sample into a clean container and check for the presence of water or solids. Slight discoloration of the oil should not necessitate an oil change.

## TROUBLESHOOTING

Although Tuthill Vacuum & Blower Systems blowers are well designed and manufactured, problems may occur due to normal wear and the need for readjustment. The following chart lists symptoms that may occur along with probable causes and remedies.

SYMPTOM	PROBABLE CAUSE	REMEDIES
Loss of oil	Gear housing not tightened properly	Tighten gear housing bolts.
	Lip seal failure	Disassemble and replace lip seal.
	Insufficient sealant	Remove gear housing and replace sealant. <b>See <i>Disassembly (3200 and 4600) on page 20.</i></b>
	Loose drain plug	Tighten drain plug.
Excessive bearing or gear wear	Improper lubrication	Correct oil level. Replace dirty oil. <b>See <i>Lubrication (Splash) on page 11.</i></b>
	Excessive belt tension	Check belt manufacturer's specifications for tension and adjust accordingly.
	Coupling misalignment	Check carefully, realign if necessary.
Lack of volume	Slipping belts	Check belt manufacturer's specifications for tension and adjust accordingly.
	Worn lobe clearances	Check for proper clearances. <b>See <i>Assembly Clearances on page 25.</i></b>
	Speed too low	Increase blower speed within limits.
	Obstruction in piping	Check system to ensure an open flow path.
Knocking	Blower out of time	Re-time.
	Distortion due to improper mounting or pipe strains	Check mounting alignment and relieve pipe strains.
	Excessive pressure differential	Reduce to manufacturer's recommended pressure. Examine relief valve and reset if necessary.
	Worn gears	Replace timing gears. <b>See <i>Disassembly (3200 and 4600) on page 20.</i></b>

SYMPTOM	PROBABLE CAUSE	REMEDIES
Excessive blower temperature	Too much or too little oil in gear reservoir	Check oil level. <b>See <i>Lubrication (Splash)</i> on page 11.</b>
	Too low operating speed	Increase blower speed within limits.
	Clogged filter or silencer	Remove cause of obstruction.
	Excessive pressure differential	Reduce pressure differential across the blower.
	Elevated inlet temperature	Reduce inlet temperature.
	Worn lobe clearances	Check for proper clearances. <b>See <i>Assembly Clearances</i> on page 25.</b>
Rotor end or tip drag	Insufficient assembled clearances	Correct clearances. <b>See <i>Assembly Clearances</i> on page 25.</b>
	Case or frame distortion	Check mounting and pipe strain.
	Excessive operating pressure	Reduce pressure differential.
	Excessive operating temperature	Reduce pressure differential or reduce inlet temperature.
Vibration	Belt or coupling misalignment	Check carefully. Realign if necessary.
	Lobes rubbing	Check cylinder for hot spots, and then check for lobe contact at these points. Correct clearances. <b>See <i>Assembly Clearances</i> on page 25.</b>
	Worn bearings or gears	Check condition of gears and bearings. Replace if necessary.
	Unbalanced or rubbing lobes	Possible buildup on casing or lobes, or inside lobes. Remove buildup and restore clearances.
	Driver or blower loose	Check mounting and tighten if necessary.
	Piping resonance	Check pipe supports, check resonance of nearby equipment, and check foundation.

## REPAIR AND REPLACEMENT PARTS

Regular inspection of the blower and its installation, along with complete checks on operating conditions, will pay dividends in added life and usefulness. Pay special attention to lubrication of timing gears and bearings according to the information in **Lubrication (Splash) on page 11**. Also, service the drive per the manufacturer's instructions and lubricate the coupling or check the belt drive tension. Use thermometers and gauges to make sure that blower operating temperature and pressure remain within allowed limits.

Should adjustments or replacement be needed, repairs can often be performed locally as described in this manual after obtaining the required parts. Personnel should have a good background of mechanical experience and be thoroughly familiar with the procedures outlined in this manual. For major repairs not covered in this manual, contact the nearest Tuthill Vacuum & Blower Systems service representative. When ordering parts, give all nameplate information, plus the item numbers and names as taken from the appropriate assembly drawing in this manual.

When ordering parts, supply the blower nameplate information, as well as the item number and parts description as per the parts lists and assembly drawings. Repair kits are available for all models. Consult the factory.

## FACTORY SERVICE AND REPAIR

With proper care, Tuthill Vacuum & Blower Systems blowers will give years of reliable service. The parts are machined to close tolerances and require special tools by mechanics who are skilled at this work. Should major repairs become necessary, contact the factory for the location of the nearest service facility.

### NOTICE

*Current regulations require Material Safety Data Sheet to be completed and forwarded to Tuthill Corporation on any unit being returned for any reason which has been handling or involved with hazardous gases or materials. This is for the protection of the employees of Tuthill Corporation who are required to perform service on this equipment. Failure to do so will result in service delays.*

### NOTICE

*When returning a blower to the factory for repair, under warranty, please note the factory will not accept any unit that arrives without authorization. Contact the Service Department for return authorization.*

# 06

## DISASSEMBLY AND REASSEMBLY INSTRUCTIONS

### DISASSEMBLY (3200 AND 4600)

1. Remove all oil drain plugs and vent plugs from both ends of the blower. Before removing any parts, match-mark each component with a punch. This will allow the blower to be reassembled with the components in the same position. Match-mark the covers, end plate, housing, and both rotors.
2. Remove the drive key from the drive shaft. Remove the gear end cover. Remove the drive end cover. This is best accomplished by using two small pry bars at the dowel pins. Tap on the cover with a mallet while putting pressure on the cover with the pry bar. The cover will slowly move off the dowel pins. Inspect the drive shaft for grooves and burrs. Remove the drive shaft seal from the drive end cover.
3. Carefully remove the drive seal wear ring from the drive shaft. The simplest method to do so is to use a cut-off wheel and a die grinder. The hardened ring will typically snap open once it is cut most of the way through.
4. Remove the washer from the rotor shafts on the gear end. Remove the oil slinger assemblies.
5. Rotate the blower. Remove bolts and washers from rotor shafts on the gear end. Remove the timing gear bolts completely from the driven rotor. Remove the timing gear from the rotor shaft by using a gear puller. **See Figure 6-1.** Rotate the gear as it is being removed to prevent binding. Inspect the gear teeth for wear and pitting. Inspect the rotor shaft keyway for wear and damage.
6. Remove the bolts from the free end of the end plate.

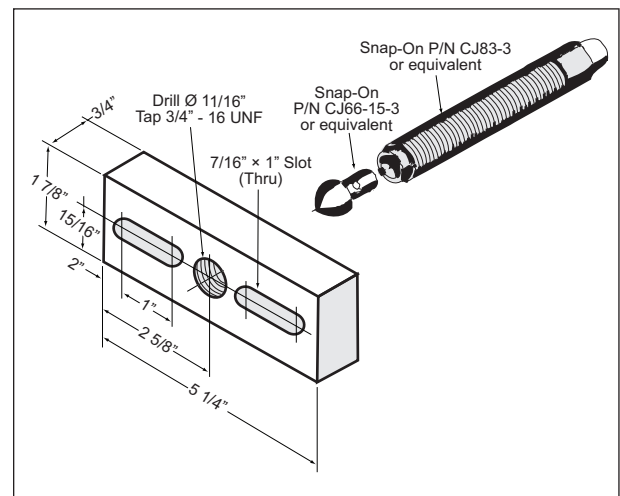

Figure 6-1 – Bar Puller



7. Use one of the following methods to remove the seal assembly from the drive end of the end plate:
  - Use 4 jacking screws on the end plate to apply even pressure to the jack screws to push the end plate from the housing. Remove the screws. Remove the retainer plate. Push the rotors out of the gear end end plate. Remove the bearings and bearing shield. Save the shims and measure for proper clearance for rebuilding the blower. Remove the seal assembly from the end plate.
  - Using a large arbor press, orient the blower drive shaft down, supported by the ports and use a straight bar (such as a puller bar shown in **Figure 6-1**) to put even pressure on the gear end of the rotors. Once the rotors are pressed to flush with the bearings, insert metric bolts into the rotor or use a spacer slightly smaller than the shaft diameter to press the rotors through the bearings. Save shims and measure for proper clearance for rebuilding the blower. Remove the seal assembly from the end plate.
  - Reverse the machine to drive the shaft up and press each rotor free from the drive end end plate.

8. Remove the seals from the rotors with a plastic mallet or by tapping toward the end of the rotor shaft.
9. Remove the bearings, bearing shield, and seal assembly out of the free end end plates.

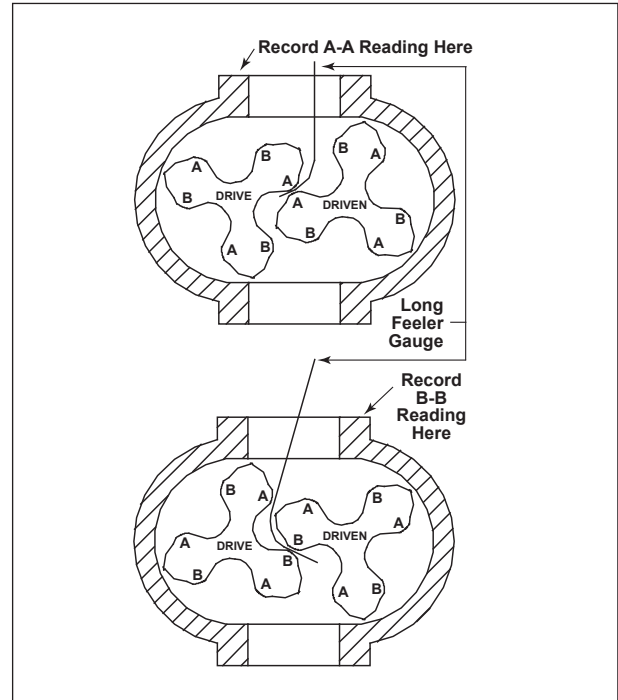

Figure 6-4 – Checking Rotor Interlobe Clearance

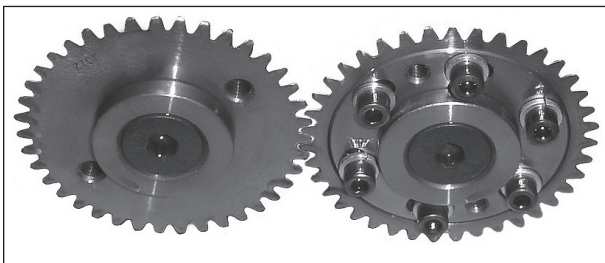

Figure 6-2 – Gear Alignment

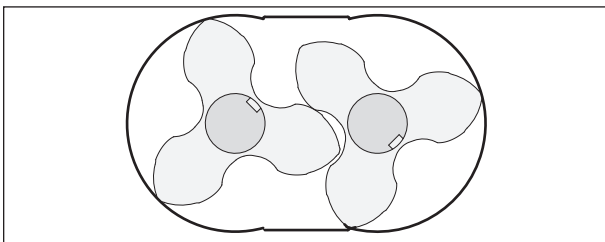

Figure 6-3 – Lobe Keyway Position

10. Use a hammer and brass bar to drive bearing and seal housing from end plates. Inspect bearing wear pattern and seal for wear and heat marks. Clean all parts before inspecting. Check the rotors' bearing and seal fits for bearing spinning along with the seal housing on the rotor shaft. Check the bearing bores and seal bores in the end plate for spinning of bearings and seal housing.

## DISASSEMBLY (6000 SERIES)

1. Remove all oil drain plugs and vent plugs from both ends of the blower. Before removing any parts, match-mark each component with a punch. This will allow the blower to be reassembled with the components in the same position. Match-mark the covers, endplate, housing, and both rotors.
2. Remove drive key from drive shaft. Remove gear end cover. Remove drive end cover. This is best accomplished by using two small pry bars at the dowel pins. Tap on cover with a mallet while putting pressure on the cover with the pry bar. The cover will slowly move off the dowel pins. Inspect the drive shaft for grooves and burrs. Remove drive shaft seal from drive end cover.
3. Carefully remove the drive seal wear ring from the drive shaft. The simplest method to do so is to use a cut-off wheel and a die grinder. The hardened ring will typically snap open once it is cut most of the way through.
4. Remove washer from the rotor shaft on the drive end. Remove oil slinger assemblies. Remove bolts from drive end endplate.
5. Use 4 jacking screws on drive end endplate. Apply even pressure to jack screws to push the endplate from housing and rotor shafts. Remove shims from endplate. Remove bearings and seal assembly from endplate. Rotate unit. Remove bolts and washers from rotor shafts on the gear end. Remove the timing gear bolts completely from the driven rotor. Remove the timing gear from the rotor shaft by using a gear puller. **See Figure 6-1.** Rotate the gear as it is being removed to prevent binding. Inspect gear teeth for wear and pitting. Remove rotor key from keyways. Inspect rotor shaft keyway for wear and damage.
6. Remove bolts from gear end endplate.
7. Use 4 jacking screws on the gear end endplate. Apply even pressure to the jack screws to push the end plate from the housing. Remove screws. Remove retainer plate. Push rotors out of gear end endplate. Remove

bearings and remove bearing shield. Save shims and measure for proper clearance for rebuilding the unit. Remove seal assembly from the endplate. OR Using a large arbor press, orient the blower drive shaft down, supported by the ports and use a straight bar (such as a puller bar shown in **Figure 6-1**) to put even pressure on the gear end of the rotors. Once the rotors are pressed to flush with the bearings, insert metric bolts in to the rotor or use a spacer slightly smaller than the shaft diameter to press the rotors through the bearings. Save shims and measure for proper clearance for rebuilding the unit. Remove seal assembly from endplate.

8. Remove seals from the rotors with a plastic mallet or by tapping towards the end of the rotor shaft.
9. Use a hammer and brass bar to drive bearing and seal housing from endplates. Inspect bearing wear pattern and seal for wear and heat marks. Clean all parts before inspecting. Check the rotors' bearing and seal fits for bearing spinning along with seal housing on the rotor shaft. Check bearing bores and seal bores in the endplate for spinning of bearings and seal housing.

## ASSEMBLY (3200 AND 4600)

A maintenance kit containing all the components that are replaced during a normal blower overhaul is available from Tuthill Vacuum and Blower Systems. Be sure to have these parts, at a minimum, on hand prior to assembly. Be certain to have your serial number available when you contact the factory.

Check all parts to make sure they are clean and free of burrs or nicks that may have occurred when the blower was being disassembled. Check the repair kit for the correct parts needed to complete the assembly of the blower. Make sure you have the proper tooling and training required to assemble the blower. Take the proper time to read the manual before you begin.

**Gear End Assembly (3200 and 4600)**

1. Seat the rotors on a fixture with the gear end of the rotors upward and in the "T" position. Make sure the drive rotor is in the correct location for the proper flow and rotation required for the application.
2. Install the end plate and housing assembly onto the rotors. Using a seal pressing tool, press the seal assembly onto the rotor shafts and into the bores of the end plates. Add shims as needed. Install the seal slinger. Add shims as needed. Press the oil shield onto the rotor shafts. The oil shield is part of the seal assembly, but it must be pressed on after the seal assembly is installed.
3. Install the bearings press until seated. Install the retainer and bolts. Install the keys into the shaft. Install the gear assembly. Install the solid gear onto the long-tail drive rotor and two-piece gear onto the driven rotor. Install the locks. Install the screws.

**Drive End (Free End) Assembly (3200 and 4600)**

1. Turn the blower over. Set on the face of the gears and with feeler gauges check the gear end for proper clearances.
2. **See Figure 6-5** regarding bearing bore stack up and seal measurement.
3. Put depth micrometer on the housing and measure the distance to the rotor face or use flat block and feeler gauge. Add shims to get proper free end clearances. Install O-ring into groove.
4. Install end plate onto dowels. Bolt down with screws. With feeler gauge, check free end clearance. Adjust with shims appropriately.
5. Install seal assembly onto rotor shafts and into end plates. Press the slinger onto the shaft. Press the oil shield onto the shaft. Install the bearings. Install the slingers. Tighten the set screws into the shaft. Install the washer and install flat-head cap screw into the end of the shaft.

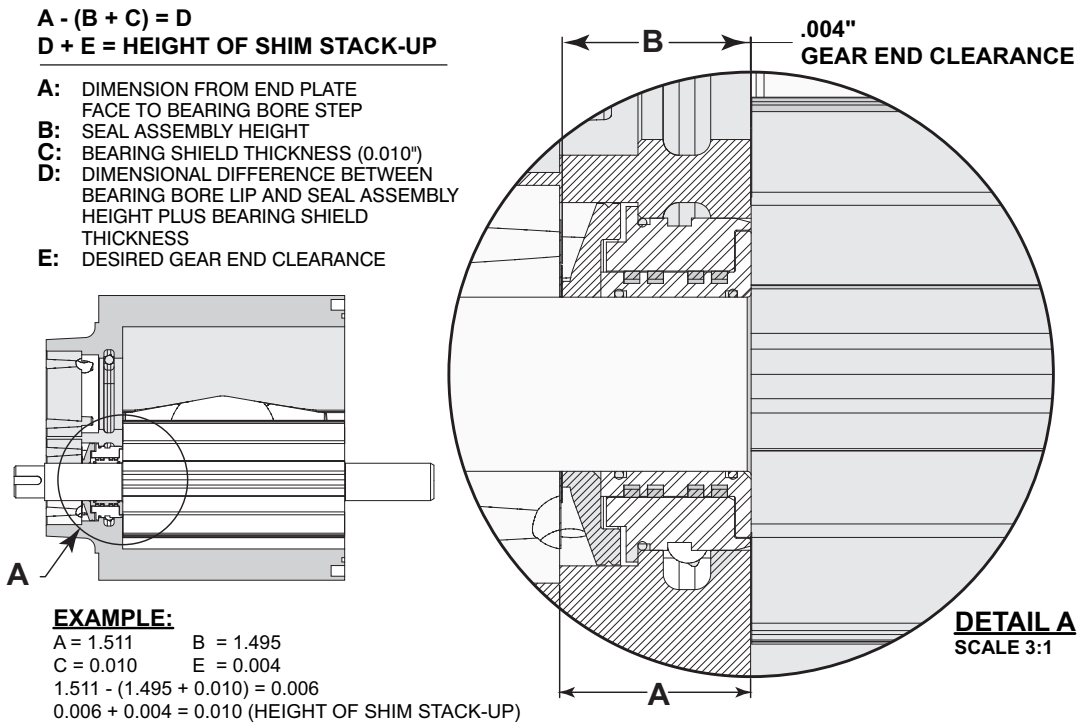

Figure 6-5 – Bearing Bore Stack-Up and Seal Measurement

## ASSEMBLY (6000 SERIES)

A maintenance kit is available from Tuthill Vacuum and Blower Systems. This kit contains all the components that are replaced during a normal blower overhaul. As a minimum, these parts should be on hand prior to assembly. Be certain to have your serial number available when you contact the factory.

Check all parts to insure they are clean and free of burrs or nicks that may have occurred when the blower was being disassembled. Check the repair kit for the correct parts needed to complete the assembly of the unit. Make sure you have the proper tooling and training required to assemble the blower. Take the proper time to read the instruction manual before you begin.

### Gear End Assembly (6000 Series)

1. Seat rotors on a fixture with the gear end of the rotors upward and with the rotor keyways pointing toward the 9 o'clock position. Make sure that the drive rotor is in the correct location for the proper flow and rotation required for the application.
2. **See Figure 6-5** regarding bearing bore stack-up and seal measurement.
3. Using a seal pressing tool, press the piston carrier onto the rotor shaft, and sleeves into the bores of endplates. Seat endplate over rotors. Install seal slingers and add shims as needed.
4. Install bearings and press until seated. Install retainer and bolts. Install gear spacer onto long-tail rotor.
5. Install keys into shaft. Install solid gear onto long-tail rotor and two-piece gear hub onto driven rotor. Install two-piece gear over hub. Install lock washers and screws into gear. Install rotor washers and screws over gears.
6. Check clearances. Add O-ring to housing. Add entire assembly to housing and bolt together.

### Drive End (Free End) Assembly (6000 Series)

1. Turn unit over and set on face of gear and with feeler gauges check the free end for proper clearances. Add shims to get proper free end clearances. Install O-ring into groove.
2. Install piston carriers onto rotor shafts and sleeves into endplate bores.
3. Install endplate over rotor shafts and bolt to the housing.
4. With a feeler gauge, check free end clearance. Adjust with shims appropriately.
5. Install slingers onto each shaft and add .060 in. shims to each shaft. Install bearings.
6. Add bearing spacers. Install washers and bolts to hold bearing spacers. Add the inner race retainer to the drive rotor and tighten set screws.
7. Add spacers and oil slinger to the driven rotor and lock down using rotor washers.
8. Add wear ring to the drive rotor using wear ring tool.
9. Check all clearances and set timing. **See Figure 6-4 on page 21** to set Interlobe clearances.

## ASSEMBLY CLEARANCES

MODEL	GEAR END	DRIVE END	TOTAL CLEARANCE	INTERLOBE	TIP TO DOWEL	TIP TO PORT
3203	0.003 – 0.006 in. 0.08 – 0.15 mm	0.005 – 0.007 in. 0.13 – 0.18 mm	0.008 – 0.013 in. 0.20 – 0.33 mm	0.004 – 0.008 in. 0.10 – 0.20 mm	0.002 – 0.005 in. 0.05 – 0.13 mm	0.005 – 0.007 in. 0.13 – 0.18 mm
3205	0.003 – 0.006 in. 0.08 – 0.15 mm	0.008 – 0.010 in. 0.20 – 0.25 mm	0.011 – 0.016 in. 0.28 – 0.41 mm	0.004 – 0.008 in. 0.10 – 0.20 mm	0.002 – 0.005 in. 0.05 – 0.13 mm	0.005 – 0.007 in. 0.13 – 0.18 mm
3208	0.003 – 0.006 in. 0.08 – 0.15 mm	0.011 – 0.014 in. 0.28 – 0.36 mm	0.014 – 0.020 in. 0.36 – 0.51 mm	0.004 – 0.008 in. 0.10 – 0.20 mm	0.002 – 0.005 in. 0.05 – 0.13 mm	0.005 – 0.007 in. 0.13 – 0.18 mm
3213	0.003 – 0.006 in. 0.08 – 0.15 mm	0.016 – 0.019 in. 0.41 – 0.48 mm	0.019 – 0.025 in. 0.48 – 0.64 mm	0.004 – 0.008 in. 0.10 – 0.20 mm	0.004 – 0.008 in. 0.10 – 0.20 mm	0.009 – 0.011 in. 0.23 – 0.28 mm
4606	0.003 – 0.006 in. 0.08 – 0.15 mm	0.009 – 0.012 in. 0.23 – 0.30 mm	0.012 – 0.019 in. 0.30 – 0.48 mm	0.005 – 0.011 in. 0.13 – 0.28 mm	0.002 – 0.005 in. 0.05 – 0.13 mm	0.006 – 0.008 in. 0.15 – 0.20 mm
4610	0.003 – 0.006 in. 0.08 – 0.15 mm	0.014 – 0.017 in. 0.36 – 0.43 mm	0.017 – 0.024 in. 0.43 – 0.61 mm	0.005 – 0.011 in. 0.13 – 0.28 mm	0.002 – 0.005 in. 0.05 – 0.13 mm	0.006 – 0.008 in. 0.15 – 0.20 mm
4616	0.003 – 0.006 in. 0.08 – 0.15 mm	0.020 – 0.023 in. 0.51 – 0.58 mm	0.023 – 0.030 in. 0.58 – 0.76 mm	0.005 – 0.011 in. 0.13 – 0.28 mm	0.004 – 0.008 in. 0.10 – 0.20 mm	0.009 – 0.011 in. 0.23 – 0.28 mm
6009	0.002 – 0.005 in. 0.05 – 0.013 mm	0.018 – 0.022 in. 0.46 – 0.56 mm	0.022 – 0.025 in. 0.56 – 0.64 mm	0.015 – 0.016 in. 0.38 – 0.41 mm	0.004 – 0.007 in. 0.10 – 0.18 mm	0.007 – 0.009 in. 0.18 – 0.23 mm
6015	0.002 – 0.005 in. 0.05 – 0.013 mm	0.020 – 0.024 in. 0.51 – 0.61 mm	0.024 – 0.027 in. 0.61 – 0.69 mm	0.015 – 0.016 in. 0.38 – 0.41 mm	0.004 – 0.007 in. 0.10 – 0.18 mm	0.007 – 0.009 in. 0.18 – 0.23 mm
6024	0.002 – 0.005 in. 0.05 – 0.013 mm	0.021 – 0.025 in. 0.53 – 0.64 mm	0.025 – 0.028 in. 0.64 – 0.71 mm	0.015 – 0.016 in. 0.38 – 0.41 mm	0.004 – 0.007 in. 0.10 – 0.18 mm	0.009 – 0.011 in. 0.23 – 0.28 mm

# 08

## RECOMMENDED LUBRICANTS FOR ROTARY BLOWERS AND VACUUM BOOSTERS

RECOMMENDED SYNTHETIC BASED, FOOD GRADE LUBRICANTS		
AMBIENT TEMPERATURE	LUBRICANT MEETING U.S. FDA REGULATION 21 CFR 178.3570 GOVERNING PETROLEUM PRODUCTS WHICH MAY HAVE INCIDENTAL CONTACT WITH FOOD, AND USDA H1 REQUIREMENTS	LUBRICANT MEETING U.S. FDA REGULATIONS 21 CFR 172.878 AND 178.3620(A) FOR DIRECT AND INDIRECT FOOD CONTACT
0° to 32°F (-18° to 0°C)	<b>PneuLube™ FG</b> (ISO 100)	CONSULT FACTORY
32° to 90°F (0° to 32°C)		
90° to 120°F* (32° to 50°C)		

RECOMMENDED LUBRICANTS FOR M-D VACUUM BOOSTERS
REQUIREMENTS
<ul style="list-style-type: none"> <li>• Suitable for high vacuum service</li> <li>• 100 cSt @ 40°C</li> <li>• Vapor pressure of 1 micron or less @ 70°F (21°C)</li> <li>• Straight mineral (no additives) or PAO synthetic oil</li> </ul>

RECOMMENDED GREASE FOR COMPETITOR® PLUS BLOWERS:	
TUTHILL	CITGO
Tuthill PneuLube™ NLGI #2 premium grade, petroleum base lithium grease.	<b>For food grade requirements:</b> Use Citgo Clarion® Food Grade HTEP grease, NLGI No. 2 grade. It meets all requirements of FDA Regulation 21 CFR 178.3570 (the former USDA H-1 approval requirements) for lubricants having incidental contact with food.

\* For higher ambient temperatures, please consult the factory.

\*\* Blowers used in oxygen-enriched service should use only Castrol Brayco 1726 Plus non-flammable, PFPE synthetic lubricant. Blowers used in hydrogen service should use only PneuLube synthetic oil. Tuthill Vacuum & Blower Systems cannot accept responsibility for damage to seals, O-rings and gaskets caused by use of synthetic lubricants not recommended by Tuthill Vacuum and Blower Systems.

This Page Intentionally Left Blank

# 09

## CUTAWAY DRAWINGS AND PARTS LISTS

### CUTAWAY DRAWING FOR QX-3200 AND QX-4600 SERIES BLOWERS

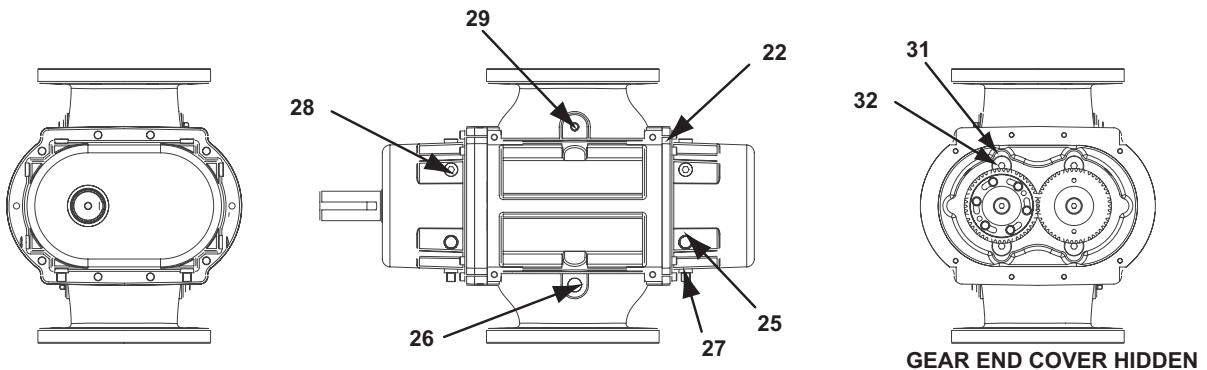
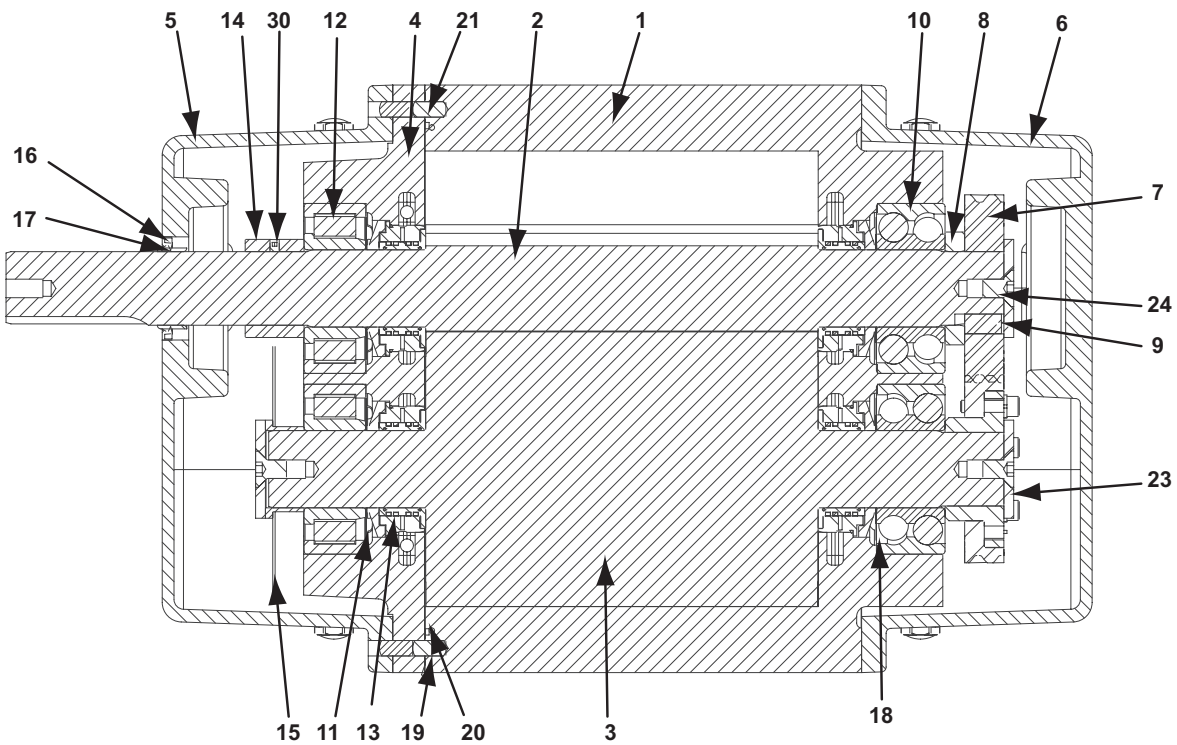



## PARTS LIST FOR QX-3200 AND QX-4600 SERIES BLOWERS

ITEM NO.	PART DESCRIPTION	QTY
1	HOUSING	1
2	DRIVE ROTOR	1
3	DRIVEN ROTOR	1
4	ENDPLATE	1
5	DRIVE COVER	1
6	GEAR END COVER	1
7	GEAR ASSEMBLY	1
8	GEAR SPACER	1
9	GEAR KEY	2
10	BALL BEARING	2
11	BEARING SHIELD	4
12	CYLINDER BEARING	2
13	SEAL ASSEMBLY	4
14	DRIVE COLLAR	1
15	OIL SLINGER	1
16	LIP SEAL	1

ITEM NO.	PART DESCRIPTION	QTY
17	SEAL WEAR RING	1
18	BEARING SHIM	–
19	HOUSING SHIM	–
20	O-RING	1
21	DOWEL PIN	4
22	CAP SCREW	26
23	ROTOR WASHER	3
24	FLAT CAP SCREW	3
25	OIL SIGHT GLASS	4
26	HEX PIPE PLUG	2
27	OIL DRAIN PLUG	4
28	SOCKET PIPE PLUG	8
29	SQUARE PIPE PLUG	2
30	SET SCREW	2
31	WASHER	4
32	CAP SCREW	4

### CUTAWAY DRAWING FOR QX-6000 SERIES BLOWERS

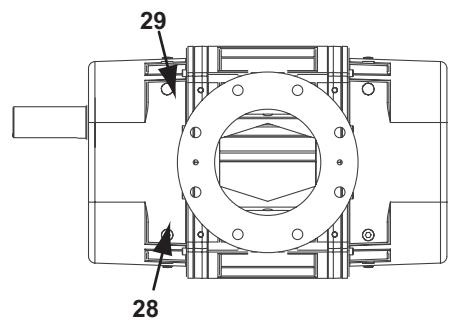
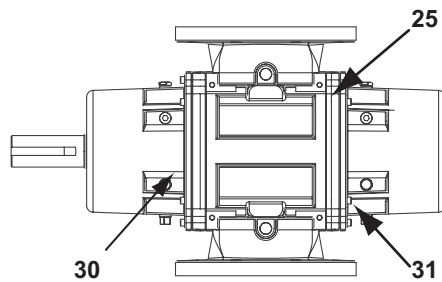
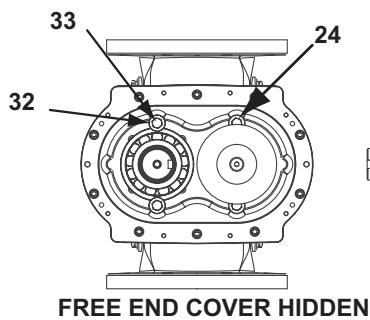
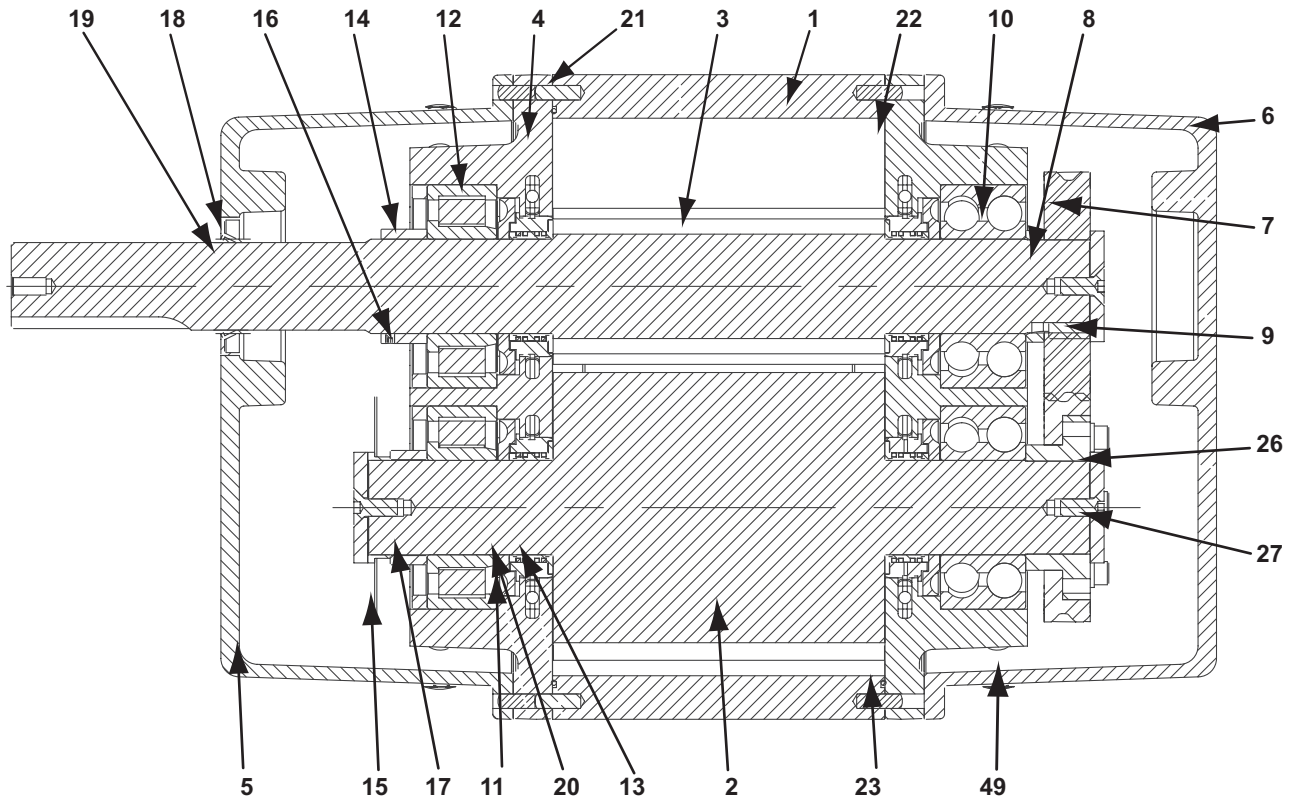

## PARTS LIST FOR QX-6000 SERIES BLOWERS

ITEM NO.	PART DESCRIPTION	QTY
1	HOUSING	1
2	DRIVEN ROTOR	1
3	DRIVE ROTOR	1
4	ENDPLATE	2
5	DRIVE COVER	1
6	GEAR END COVER	1
7	GEAR ASSEMBLY	1
8	GEAR SPACER	1
9	TIMING GEAR KEY	2
10	BALL BEARING	2
11	BEARING SHIELD	4
12	CYLINDER BEARING	2
13	SEAL ASSEMBLY	4
14	DRIVE COLLAR	1
15	OIL SLINGER	1
16	SET SCREW	2
17	OIL SLINGER SPACER	1

ITEM NO.	PART DESCRIPTION	QTY
18	LIP SEAL	1
19	SEAL WEAR RING	1
20	BEARING SHIM	–
21	HOUSING SHIM	–
22	ORING	2
23	DOWEL PIN	6
24	CAP SCREW	16
25	CAP SCREW	20
26	ROTOR WASHER	3
27	FLAT CAP SCREW	3
28	SOCKET PIPE PLUG	8
29	HEX PIPE PLUG	6
30	OIL SIGHT GLASS	4
31	OIL DRAIN PLUG	2
32	WASHER	8
33	CAP SCREW	8



## DECLARATION OF INCORPORATION

Herewith we declare that the items detailed below are in conformity with the provisions of the Machinery Directive 2006/42/EC.

Information on the items detailed are compiled per the Machinery Directive 2006/42/EC, Annex VII, part A and are the responsibility of the person listed below.

The items detailed below must not be put into service until the machinery into which it is to be incorporated has been declared in conformity with the provisions of the relevant directive(s).

Other directives and standards that apply to this Declaration of Incorporation:

EN 1012-1:1996 - Compressors and vacuum pumps - Safety requirements - Part 1:  
Compressors

The scope of the Declaration of Incorporation is for bare shaft Rotary Positive Displacement (PD Plus) Blowers

Models 3200, 4600, 6000

David Schardt  
Vice President of Engineering, Tuthill Vacuum & Blower Systems



Tuthill Vacuum & Blower Systems  
4840 West Kearney Street  
P.O. Box 2877  
Springfield, MO USA 65801-0877

## WARRANTY – BLOWER PRODUCTS

Subject to the terms and conditions hereinafter set forth and set forth in General Terms of Sale, Tuthill Vacuum & Blower Systems (the Seller) warrants products and parts of its manufacture, when shipped, and its work (including installation and start-up) when performed, will be of good quality and will be free from defects in material and workmanship. This warranty applies only to Seller's equipment, under use and service in accordance with seller's written instructions, recommendations and ratings for installation, operating, maintenance and service of products, for a period as stated in the table below. Because of varying conditions of installation and operation, all guarantees of performance are subject to plus or minus 5% variation. (Non-standard materials are subject to a plus or minus 10% variation)

PRODUCT TYPE	TYPE OF APPLICATION	
	ATMOSPHERIC AIR OR PROCESS AIR WITHOUT LIQUIDS PRESENT	PROCESS GASES OTHER THAN AIR, OR ANY LIQUID INJECTED APPLICATION
<b>New</b> <i>(Qx™ models only)</i>	30 months from date of shipment, or 24 months after initial startup date, whichever occurs first.	Consult Factory
<b>New</b> <i>(all other models)</i>	24 months from date of shipment, or 18 months after initial startup date, whichever occurs first	18 months from date of shipment, or 12 months after initial startup date, whichever occurs first
<b>Repair</b>	12 months from date of shipment, or remaining warranty period, whichever is greater	12 months from date of shipment, or remaining warranty period, whichever is greater

THIS WARRANTY EXTENDS ONLY TO BUYER AND/OR ORIGINAL END USER, AND IN NO EVENT SHALL THE SELLER BE LIABLE FOR PROPERTY DAMAGE SUSTAINED BY A PERSON DESIGNATED BY THE LAW OF ANY JURISDICTION AS A THIRD PARTY BENEFICIARY OF THIS WARRANTY OR ANY OTHER WARRANTY HELD TO SURVIVE SELLER'S DISCLAIMER.

All accessories furnished by Seller but manufactured by others bear only that manufacturer's standard warranty.

All claims for defective products, parts, or work under this warranty must be made in writing immediately upon discovery and, in any event within one (1) year from date of shipment of the applicable item and all claims for defective work must be made in writing immediately upon discovery and in any event within one (1) year from date of completion thereof by Seller. Unless done with prior written consent of Seller, any repairs, alterations or disassembly of Seller's equipment shall void warranty. Installation and transportation costs are not included and defective items must be held for Seller's inspection and returned to Seller's Ex-works point upon request.

THERE ARE NO WARRANTIES, EXPRESSED, IMPLIED OR STATUTORY WHICH EXTEND BEYOND THE DESCRIPTION ON THE FACE HEREOF, INCLUDING WITHOUT LIMITATION, THE IMPLIED WARRANTIES OF MERCHANTABILITY AND FITNESS OF PURPOSE.

After Buyer's submission of a claim as provided above and its approval, Seller shall at its option either repair or replace its product, part, or work at the original Ex-works point of shipment, or refund an equitable portion of the purchase price.

The products and parts sold hereunder are not warranted for operation with erosive or corrosive material or those which may lead to build up of material within the product supplied, nor those which are incompatible with the materials of construction. The Buyer shall have no claim whatsoever and no product or part shall be deemed to be defective by reason of failure to resist erosive or corrosive action nor for problems resulting from build-up of material within the unit nor for problems due to incompatibility with the materials of construction.

Any improper use, operation beyond capacity, substitution of parts not approved by Seller, or any alteration or repair by others in such manner as in Seller's judgment affects the product materially and adversely shall void this warranty.

No employee or representative of Seller other than an Officer of the Company is authorized to change this warranty in any way or grant any other warranty. Any such change by an Officer of the Company must be in writing.

The foregoing is Seller's only obligation and Buyer's only remedy for breach of warranty, and except for gross negligence, willful misconduct and remedies permitted under the General Terms of Sale in the sections on CONTRACT PERFORMANCE, INSPECTION AND ACCEPTANCE and the PATENTS Clause hereof, the foregoing is BUYER'S ONLY REMEDY HEREUNDER BY WAY OF BREACH OF CONTRACT, TORT OR OTHERWISE, WITHOUT REGARD TO WHETHER ANY DEFECT WAS DISCOVERED OR LATENT AT THE TIME OF DELIVERY OF THE PRODUCT OR WORK. In no event shall Buyer be entitled to incidental or consequential damages. Any action for breach of this agreement must commence within one (1) year after the cause of action has occurred.

May 2008

## OPERATING DATA FORM / PRODUCT REGISTRATION

It is to the user's advantage to have the requested data filled in below and available in the event a problem should develop in the blower or the system. This information is also helpful when ordering spare parts.

Model No.	_____	V-Belt Size	_____	Length	_____
Serial No.	_____	Type of Lubrication	_____		
Start-up Date	_____				
Pump RPM	_____	Operating Vacuum	_____		
Pump Sheave Diameter	_____	Any Other Special Accessories Supplied or in Use:			
Motor Sheave Diameter	_____				
Motor RPM	_____	HP	_____		

**NOTES:**

\_\_\_\_\_

\_\_\_\_\_

\_\_\_\_\_

### IMPORTANT

All blowers manufactured by Tuthill Vacuum & Blower Systems are date-coded at time of shipment. In order to assure you of the full benefits of the product warranty, please complete, tear out and return the product registration card, or register online at [tuthillvacuumblower.com](http://tuthillvacuumblower.com).





**For Service & Repair, Technical  
Support, or Product Sales contact:**

Tuthill Vacuum & Blower Systems  
4840 West Kearney Street  
Springfield, Missouri USA 65803-8702  
O 417.865.8715 800.825.6937  
F 417.865.2950  
tuthillvacuumblower.com



**Manual 2010 Rev A p/n 2010**

2/18